

PPCH-G™

High Pressure Controller/Calibrator

Technical Data

High performance pressure control
to 100 MPa (15 000 psi)



Features

- Pressure “ready/not ready” indicator with user adjustable criteria
- Intelligent AutoZero™ function
- 16 SI and US pressure units
- Automatic fluid pressure head correction
- On board, programmable calibration sequences with DUT tolerance testing
- Remote [ENTER] footswitch for hands free test execution
- Valve drivers option for system design
- Automated leak testing routines
- RS-232 and IEEE-488 communications
- FLASH memory for simple and free embedded software upgrades from www.dhainstruments.com.

PPCH-G™, is a pressure controller/calibrator for gas pressure operation from 1 to 100 MPa (150 to 15 000 psi). As with the rest of DHI’s PPC family of pressure controllers, the emphasis is on high end performance, minimizing measurement uncertainty and maintaining precise control over a very wide pressure range—in a compact and rugged instrument.

Individually characterized, quartz reference pressure transducer (Q-RPT) modules increase precision and reduce measurement uncertainty. The AutoRange™ feature supports infinite ranging, automatically optimizing all aspects of operation for the exact desired range and taking pressure controller rangeability to a new level.

A unique pressure control system and gas booster accessory provide unlimited, on-demand pressure, very high control resolution and 10:1 pressure control turndown. Five different control modes are included for maximum versatility. Open architecture allows reference pressure measurement to be internal to or remote from the controller. If desired, the reference can be located at the test measurement point and independently removed for recalibration.

With all of this, PPCH-G opens new doors in automated high gas pressure calibration and test applications.

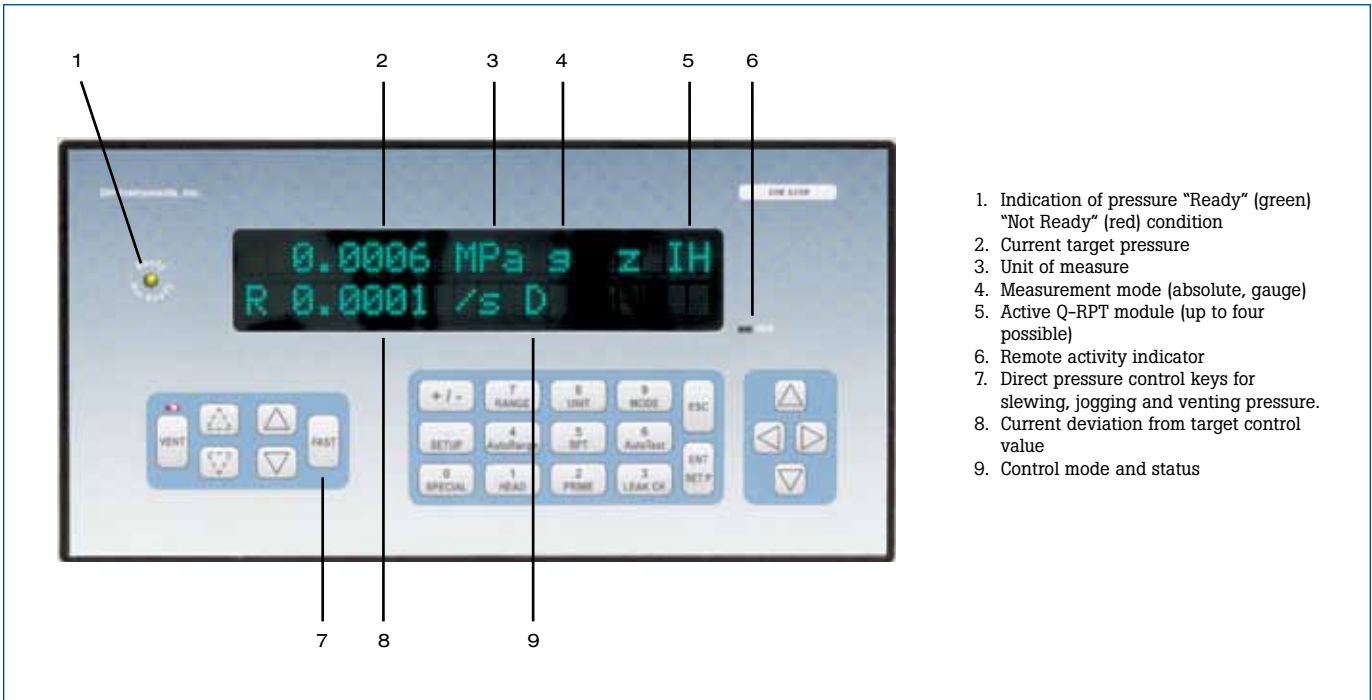

1. Indication of pressure "Ready" (green) "Not Ready" (red) condition
2. Current target pressure
3. Unit of measure
4. Measurement mode (absolute, gauge)
5. Active Q-RPT module (up to four possible)
6. Remote activity indicator
7. Direct pressure control keys for slewing, jogging and venting pressure.
8. Current deviation from target control value
9. Control mode and status

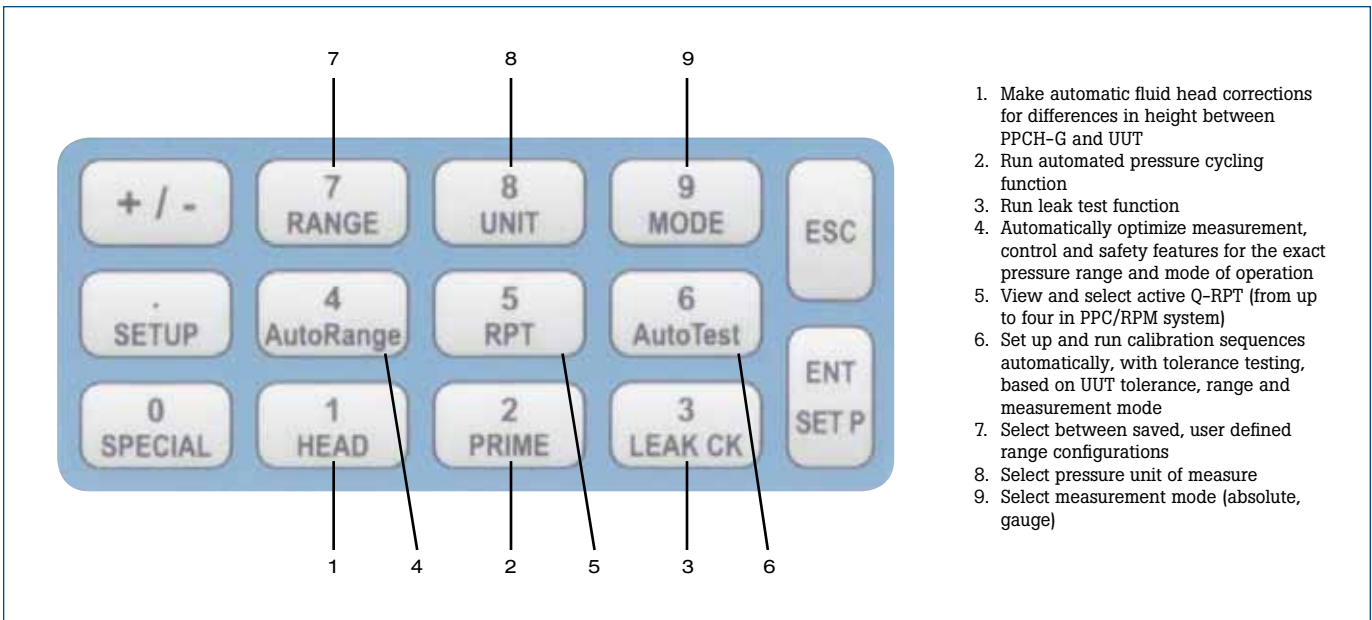

1. Make automatic fluid head corrections for differences in height between PPCH-G and UUT
2. Run automated pressure cycling function
3. Run leak test function
4. Automatically optimize measurement, control and safety features for the exact pressure range and mode of operation
5. View and select active Q-RPT (from up to four in PPC/RPM system)
6. Set up and run calibration sequences automatically, with tolerance testing, based on UUT tolerance, range and measurement mode
7. Select between saved, user defined range configurations
8. Select pressure unit of measure
9. Select measurement mode (absolute, gauge)

Quartz reference pressure transducer (Q-RPT) modules

PPCH-G's outstanding pressure measurement specifications are made possible by DHI's exclusive quartz reference pressure transducer (Q-RPT) modules.

Q-RPTs measure pressure by measuring the change in the natural oscillating frequency of a quartz crystal with pressure induced stress. To be qualified for use in a Q-RPT module, each transducer is individually evaluated and characterized using automated primary pressure standards. Only transducers exhibiting required levels of linearity, repeatability and stability are selected. A proprietary compensation model, derived from more than 15 years experience with thousands of quartz pressure transducers, is applied to optimize the metrological characteristics needed in a transfer standard.

PPCH-G can be delivered with a low cost utility sensor for applications in which the high precision and stability of a Q-RPT are not required.

Q-RPTs available for PPCH-G

Q-RPT designation	SI version Maximum range Absolute/gauge (MPa)	US version Maximum range Absolute/gauge (psi)
A100M	100	15 000
A70M	70	10 000
A40M	40	6 000
A20M	20	3 000
A10M	10	1 500
A7M	7	1 000

Infinite ranging™ and autoRange™

There's a lot more to covering a wide range of test devices with a single pressure controller than "% of reading" measurement uncertainty.

In addition to the necessary measurement uncertainty, PPCH-G offers the full pressure control and feature adaptability that are needed for true rangeability in test and calibration applications.

Infinite Ranging gives PPCH-G unprecedented versatility in adapting to a wide variety of devices to be tested. With the easy to use AutoRange function, a few simple key strokes or a single remote command string at the start of a test adapts every feature of the controller to optimize it for a specific range.

Open architecture

A PPCH-G controller can be configured with up to four Q-RPT modules. These can be internal or external to the PPCH-G controller. External Q-RPTs are in DHI RPM4™ Reference Pressure Monitors. The RPM4's Q-RPTs then become part of the PPCH-G system and are managed by PPCH-G. External Q-RPTs must be disconnected or protected by valves when PPCH-G is used at pressure greater than the external Q-RPT range.

Examples of possible PPCH-G system configurations include:

- A PPCH-G with one or two built-in Q-RPTs to act as a stand alone, "one box" controller/calibrator package.
- A PPCH-G with no internal Q-RPTs and an external Q-RPT to configure a system whose reference pressure measurement is remote from the controller. This configuration is ideal when it is advantageous for the reference to be removed from the system (e.g. for recalibration) while leaving the controller installed or to locate the reference measurement in closer proximity to the device or system under test.
- A PPCH-G with no built-in Q-RPTs to act as a low cost automated pressure setting and controlling device.
- A PPCH-G with a built-in Q-RPT to automate pressure control to a PG7202 piston gauge.

Open architecture PPCH system configuration examples

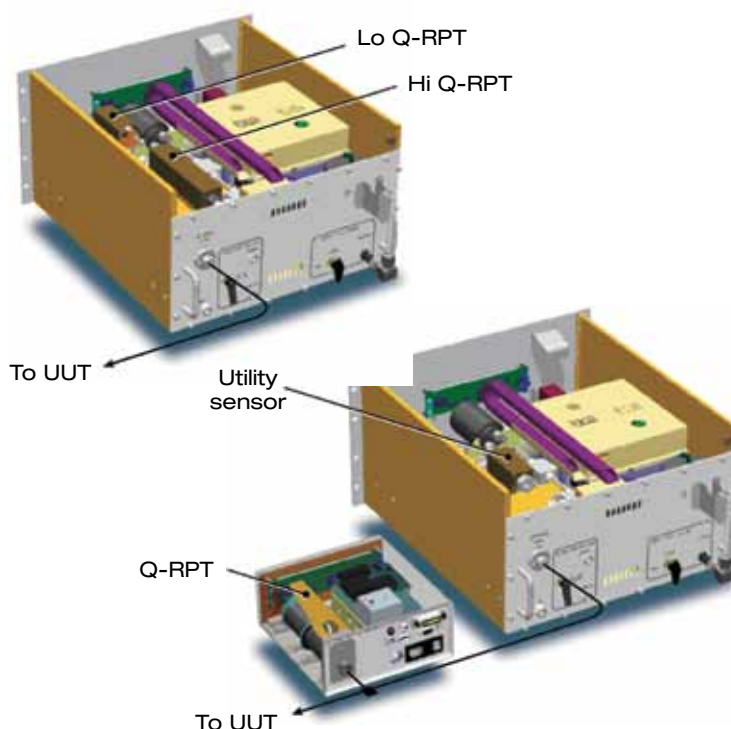

Specifications

General specifications	
Power requirements	85 V to 264 V ac, 50/60 Hz, 75 W max
Normal operating temperature	15 °C to 35 °C (59 °F to 95 °F)
Vibration	Meets MIL-T-28800D
Weight (typical)	32 kg approx (70 lb)
Dimensions (H x W x D)	30 cm x 52 cm x 50 cm (12 in x 20.5 in x 20 in) with enclosure 6U H rack mount version
Communications ports	RS-232 (COM1, COM2), IEEE-488.2
Operating modes	Absolute, gauge
Pressure ranges	Atmosphere to 100 MPa (15 000 psi)
Operating media	Nitrogen, air (others optional)
Drive air supply	500 kPa to 800 kPa (75 psi to 120 psi)
Test gas supply	Greater than maximum pressure to be controlled by at least 5 % of controller range, but not more than 15 % greater than controller range, minimum 70 % of controller range, ± 1 % stability. Flow adequate to maintain stable supply while slewing into test volume.
Pressure connections	Drive air supply: 1/8 in. NPT F Test gas supply: DH500 (equivalent to AE F250C, HIP HP4) Test: DH500
Utility sensor precision/resolution	± 0.10 % span/0.001 % span
Drivers	(8) 12 V, 1 A max total output
CE conformance	Available, must be specified

Pressure control		
Modes	Dynamic (standard and high volume)	Sets target within hold limit and continuously adjusts pressure to remain at target value
	Static	Sets target within hold limit and stops control, allowing pressure to stabilize naturally
	Monotonic	Sets pressure to target and maintains very slow ramp in same direction as pressure increment.
	Ramp	Sets and maintains user specified rate of change of pressure
	Piston gauge control	Automate piston gauge pressure control
Precision	To ± 0.001 % of Q-RPT span (standard dynamic)	
Volume	0 cc to 100 cc (0 in ³ to 6 in ³), 50 cc (3 in ³) optimum, (operates in larger volumes but pressure stabilizing time increases)	
Slew rate	0 to full scale: 60 sec., 50 cc volume	
Dynamic mode typical time to Ready	90 sec. to 120 sec. (Reduced by increasing hold limit or using monotonic control)	
Lowest controllable pressure	0.7 MPa (100 psi)	

Measured and delivered pressure (Q-RPT)		
Warm up time	30 minute temperature stabilization recommended from cold power up	
Resolution	To 1 ppm, user adjustable	
Predicted one year stability ²	± 0.005 % of reading	
Calibration	A2LA accredited calibration report included	
Q-RPTs A14M to A100M		
Precision ¹	Greater of ± 0.012 % of reading or 0.0036 % of Q-RPT span ⁵	
Measurement uncertainty ³	Greater of ± 0.013 % of reading or 0.004 % of Q-RPT span ⁵	
Delivered pressure uncertainty (dynamic control mode) ⁴	Greater of ± 0.016 % of reading or 0.005 % of Q-RPT span ⁵	
Q-RPTs A7M to A10M		
	Standard class	Premium class
Precision ¹	Greater of ± 0.008 % of reading or 0.0024 % of Q-RPT span ⁵	Greater of ± 0.005 % of reading, 0.0015 % of AutoRanged span or 0.0005 % of Q-RPT span ⁶
Measurement uncertainty ³	Greater of ± 0.010 % of reading or 0.0030 % of Q-RPT span ⁵	Greater of ± 0.008 % of reading, 0.0024 % of AutoRanged span or 0.0007 % of Q-RPT span ⁶
Delivered pressure uncertainty (dynamic control mode) ⁴	Greater of ± 0.014 % of reading or 0.004 % of Q-RPT span ⁵	Greater of ± 0.013 % of reading, 0.014 % of AutoRanged span or 0.003 % of Q-RPT span ⁶

¹ Combined linearity, hysteresis and repeatability.
² Predicted Q-RPT measurement stability limit (k=2) over one year assuming regular use of AutoZero function. AutoZero occurs automatically in gauge mode whenever vented, by comparison with barometric reference in absolute mode. Absolute mode predicted one year stability without AutoZ is ± (0.005 % Q-RPT span + 0.005 % of reading).
³ Maximum deviation of the Q-RPT indication from the true value of applied pressure including precision, predicted one year stability, temperature effect and calibration uncertainty, combined and expanded (k=2) following the ISO "Guide to the Expression of Uncertainty in Measurement."
⁴ Maximum deviation of the PPCH-G controlled pressure from the true value including measurement uncertainty and standard dynamic mode control hold limit.
⁵ % of reading applies to 30 % to 100 % of Q-RPT span. Under 30 % of Q-RPT span, uncertainty is a constant value obtained by multiplying the % of reading value by 30 % of Q-RPT span.
⁶ % of reading value times measured pressure from 100 to 30 % of AutoRanged span. Under 30 % of AutoRanged span, % of reading value times 30% of AutoRanged span. If AutoRanged span is less than 30 % of maximum Q-RPT span, % of reading values times measured pressure, or % of reading times 9% of Q-RPT span, whichever is greater.

Ordering information

Model

- PPCH-G 04-02 SI units version
- PPCH-G 05-01 CE mark
- PPCH-G 06-01 Enclosure (for bench applications)
- PPCH-G 07 Special calibration
- PPCH-G 08-SP Special fluid

Accessories

- RPM4 Reference pressure monitor for external Q-RPTs (see RPM4 brochure)
- Footswitch Remote [ENTER] footswitch
- RS-232 Cable 9 pin, 2 m for PPC3 COM1 or PPC3 to RPM4 connection
- GB-H-152-100M Gas booster package, 152:1 for 100 MPa
- GB-H-152-70M Gas booster package, 152:1 for 70 MPa

For a PPCH-G with no internal Q-RPT

PPCH-G-nnnM

Where: nnnM Indicates the PPCH-G controller's designation (100M, 70M, 40M or 20M).

For a PPCH-G with one or two internal Q-RPTs

PPCH-G-nnnM AnnnMc1/AnnnMc2

Where: nnnM Indicates the PPCH-G controller's designation.
 AnnnMc1 Indicates the Hi RPT designation. c indicates class (s for Standard, P for Premium, u for utility sensor if there is no Hi Q-RPT).
 AnnnMc2 Indicates the Lo Q-RPT designation (A70M max). c indicates class (s for Standard, P for Premium. Leave blank if there is no Lo Q-RPT).

Fluke. Keeping your world up and running.®

Fluke Calibration

PO Box 9090, Everett, WA 98206 U.S.A.

Fluke Europe B.V.

PO Box 1186, 5602 BD Eindhoven, The Netherlands

For more information call:

In the U.S.A. (800) 443-5853 or Fax (425) 446-5116
 In Europe/M-East/Africa +31 (0) 40 2675 200 or Fax +31 (0) 40 2675 222
 In Canada (800)-36-FLUKE or Fax (905) 890-6866
 From other countries +1 (425) 446-5500 or Fax +1 (425) 446-5116
 Web access: <http://www.fluke.com>

©2010 Fluke Calibration.
 Specifications subject to change without notice.
 Printed in U.S.A. 7/2010 3031137B B-EN-N

Modification of this document is not permitted without written permission from Fluke Calibration.