



# Technical data sheet for Dewar flasks with flat bottom type from FB 0 - 18 CAL

## Area of application

- laboratory technique
- medicinal technique
- Biotechnology
- for liquid or solid medias and solid matters (LN2 oder CO2)
- Pressure-less space for coolants

## Features of performance

- reliably and economically
- Dewar flasks according to DIN 12492
- glass material according to ISO 3585
- nominal capacity from 150ml to 2,1 litres
- protective casing made of stucco aluminium



Dewar flask FB 9 CAL

## Description of complete flasks

### Types and accessories

- CAL = protective casing out of stucco aluminium

### Temperature ranges

- glass refill from -200°C to + 150°C, for a short time 200°C
- casing with mounting rubber and Latizell buffer from -10°C to + 60°C

### Pressure range

- pressure - less

## Description of glass Dewar flask

### Material

- borosilicate glass 3.3 ISO 3585

### Chemical characteristics

- hydrolytic resistance: according to ISO 719 (98°C)
- hydrolytic resistance: according to ISO 720 (121°C)
- acid resistance: according to ISO 1776
- alkaline resistance: according to ISO 695-A2

### Physical characteristics

- linear expansion coefficient:  $3,3 \times 10^{-6} \text{ 1/K}$  (in between 20-300°C)
- density:  $2,23 \text{ g/cm}^3$
- specific thermal capacity:  $910 \text{ J/kg K}$
- transformation temperature:  $525^\circ\text{C}$

### Vacuum

- $> 5 \times 10^{-6} \text{ mbar}$

### Silvering

- fully silvered

## KGW -ISOTHERM

Karlsruher Glastechnisches Werk  
76185 Karlsruhe Gablonzerstraße 6  
Tel: 0721 95897-0 Fax: 0721 95897-77  
E-Mail: info@KGW-ISOTHERM.COM  
Internet: www.KGW-ISOTHERM.COM



# Technical data sheet for Dewar flasks with flat bottom type from FB 0 - 18 CAL

## Special types

- Dewar flask with loosely lied-on plug

## Safety advises and regulations

- always wear protective glasses and protective gloves
- national regulations for laboratories
- company- internal regulations
- safety regulations for handling with liquid gases

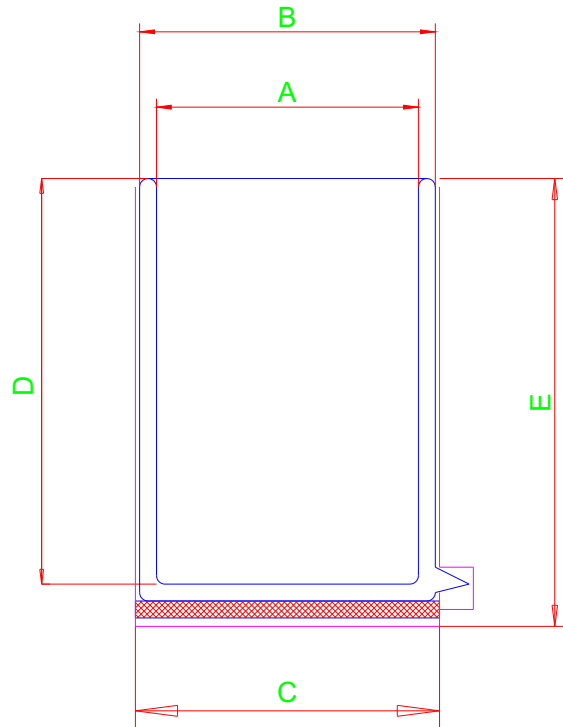

Technische Angaben / Technical Specifications										
Typ	max. Inhalt	A	B	C	D	E	Gewicht	Standzeit LN2	Verdampfungsrate LN2	
Type	max. Content						Weight	Holding time LN2	Evaporation rate LN2	
	ca. [ ml ]	mm	mm	mm	mm	mm	ca. [ kg ]	ca. [ h ]	ca. [ L / d ]	
FB 0 CAL	150	37	50	58	140	150	0,3	12	0,25	
FB 1 CAL	250	47	60	72	140	150	0,4	13	0,35	
FB 3 CAL	450	57	70	81	185	200	0,5	28	0,35	
FB 6 CAL	650	67	80	90	185	200	0,6	32	0,4	
FB 9 CAL	850	77	95	105	185	200	0,9	32	0,55	
FB 12 CAL	1200	90	115	124	185	200	1,2	33	0,7	
FB 18 CAL	2100	107	130	140	235	250	1,8	52	0,9	
Artikel-Nummern / Article numbers										
Typ	Artikel Nr.					Stopfen für Typ	Artikel Nr.			
Type	Article No.					Plug for type	Article No.			
FB 0 CAL	1151					FB 0 CAL	1651			
FB 1 CAL	1152					FB 1 CAL	1652			
FB 3 CAL	1153					FB 3 CAL	1653			
FB 6 CAL	1154					FB 6 CAL	1654			
FB 9 CAL	1155					FB 9 CAL	1655			
FB 12 CAL	1156					FB 12 CAL	1656			
FB 18 CAL	1157					FB 18 CAL	1657			